

ALTERNATORS

LSA 50.1 - 4 Pole

Electrical and mechanical data

ELECTRICAL DATA

Insulation class	H	Excitation system	A R E P + PMI
Winding pitch - Code	2/3 - (N° 6)	A.V.R. model	R 449
Leads	6	Voltage regulation (steady state)	± 0,5 %
Drip proof	IP 23	Sustained short-circuit current	300% (3 IN) : 10s
Altitude	≤ 1000 m	Total harmonic (*) TGH / THC	< 4 %
Overspeed	2250 min ⁻¹	Waveform : NEMA = TIF - (*)	< 50
Air flow	1,6 m ³ /s	Waveform : I.E.C. = THF - (*)	< 2 %

(*) Total harmonic content line to line, at no load or full rated linear and balanced load

RATINGS : kVA / kW - Power factor = 0,8

Duty/Ambiant T°	Continuous / 40°C						Stand-by / 40°C			Stand-by / 27°C			
	H / 125° K			F / 105° K			H / 150° K			H / 163° K			
	3 ph.			3 ph.			3 ph.			3 ph.			
Class/T° rise													
Phase													
Y	380V	400V	415V	380V	400V	415V	380V	400V	415V	380V	400V	415V	
Δ	220V	230V	240V	220V	230V	240V	220V	230V	240V	220V	230V	240V	
50.1 S2	kVA	910			820			960			1000		
	kW	728			656			768			800		
50.1 S4	kVA	1025			925			1075			1130		
	kW	820			740			860			904		
50.1 M6	kVA	1225			1100			1290			1350		
	kW	980			880			1032			1080		
50.1 M7	kVA	1325			1190			1390			1460		
	kW	1060			952			1112			1168		
50.1 L8	kVA	1425			1280			1500			1570		
	kW	1140			1024			1200			1256		
50.1 VL10	kVA	1580			1420			1660			1740		
	kW	1264			1136			1328			1392		

EFFICIENCIES (%) - Class H / 40° C

	Three phase : 400 V									
	P.F. = 0,8					P.F. = 1				
	1/4	2/4	3/4	4/4	St.by	1/4	2/4	3/4	4/4	St.by
50.1 S2	92,6	94,6	94,6	94,1	93,8	93,2	95,6	96	96	95,9
50.1 S4	93	94,9	95	94,5	94,3	93,6	95,9	96,3	96,2	96,1
50.1 M6	93,6	95,3	95,4	94,9	94,7	94,2	96,2	96,6	96,5	96,5
50.1 M7	93,8	95,5	95,5	95,1	94,9	94,4	96,4	96,7	96,7	96,6
50.1 L8	94	95,7	95,8	95,5	95,3	94,5	96,5	96,9	96,9	96,8
50.1 VL10	94,2	95,9	96	95,7	95,5	94,7	96,6	97	97	96,9

REACTANCES (%) - TIME CONSTANTS (ms) - CLASS H / 400 V

		50.1 S2	50.1 S4	50.1 M6	50.1 M7	50.1 L8	50.1 VL10
Kcc	Short-circuit ratio	0,331	0,343	0,352	0,349	0,371	0,382
Xd	Direct axis synchronous reactance unsaturated	395	381	377	375	353	342
Xq	Quadrature axis synchronous reactance unsaturated	237	229	226	225	212	205
T'do	Open circuit time constant	2210	2350	2520	2600	2720	2830
X'd	Direct axis transient reactance saturated	29,7	28,2	27,3	26,7	24,6	23,1
T'd	Short circuit transient time constant	196	205	214	218	222	225
X"d	Direct axis subtransient reactance saturated	16,4	15,5	15	14,8	13,5	12,7
T"d	Subtransient time constant	16	17	18	19	20	21
X"q	Quadrature axis subtransient reactance saturated	20,5	19,5	18,8	18,5	16,9	16
Xo	Zero sequence reactance unsaturated	3,9	3,7	3,5	3,5	3,2	3,0
X2	Negative sequence reactance saturated	18,5	17,5	16,9	16,5	15,2	14,3
Ta	Armature time constant	33	36	39	41	41	42

OTHER DATA - CLASS H / 400 V

		50.1 S2	50.1 S4	50.1 M6	50.1 M7	50.1 L8	50.1 VL10
io (A)	No load excitation current	1,05	1,05	1,1	1,1	1,3	1,3
ic (A)	Full load excitation current	5	4,85	4,9	4,9	5	5
uc (V)	Full load excitation voltage	63	61	62	62	63	63
ms	Recovery time (ΔU = 20 % transient)	< 500	< 500	< 500	< 500	< 500	< 500
kVA	Motor start. (ΔU = 20% sust.) or (ΔU = 50% Transient)	1820	2000	2500	2650	2850	3150
%	Transient dip (rated step load) - PF : 0,8 LAG	15	14	13,5	13	12,5	12
W	No load losses	12050	12722	13705	14199	15091	16100
W	Heat rejection	45645	47725	52665	54616	53717	56794

According to : I.E.C. 34.1/34.2 - U.T.E. : NF C 51.111 - V.D.E. 0530 - B.S. 4999 & 5000 - NEMA : MG 1.22 - ISO 8528 . 3 - CSA (C 22.2 + UL 2200).
 Products and materials shown in this catalogue may, at any time, be modified in order to follow the latest technological developments, improve the design or change the conditions of utilisation.
 Their description cannot in any case engage Leroy-Somer's liability. The values indicated are typical values .

TRANSIENT VOLTAGE VARIATION - 400V

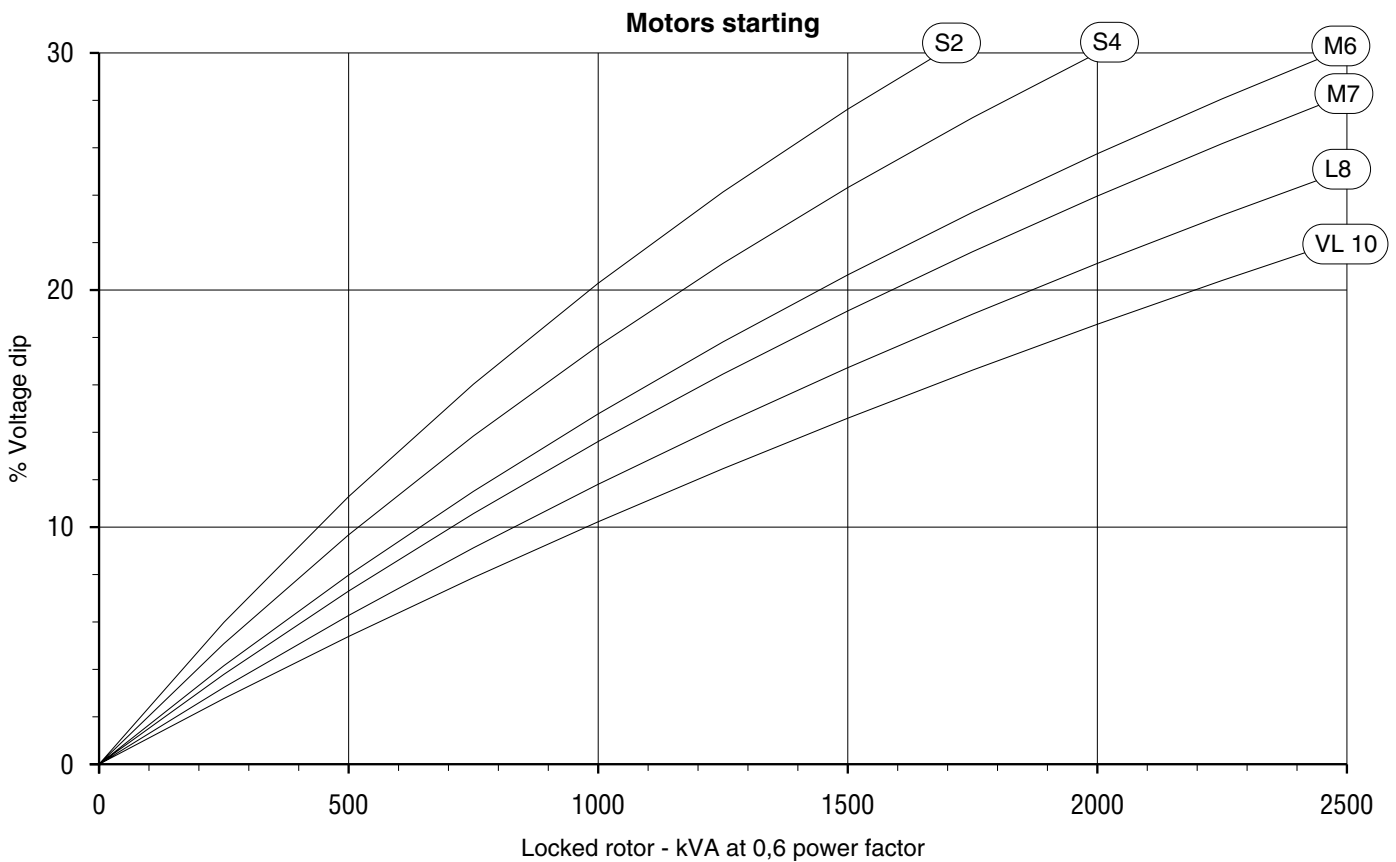
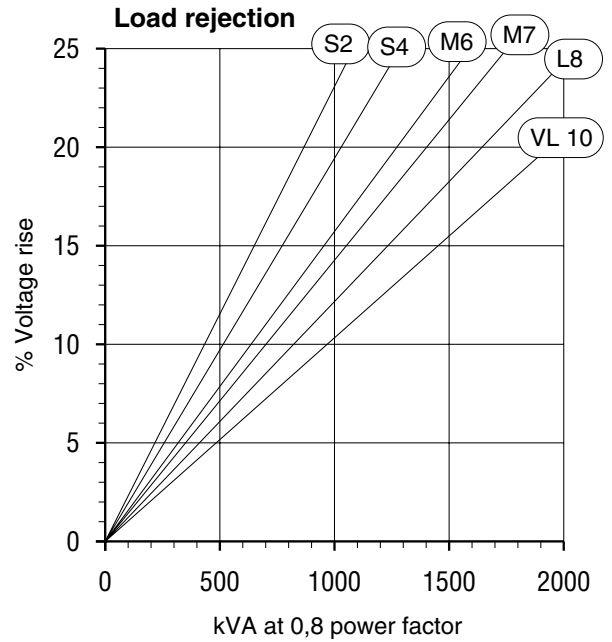
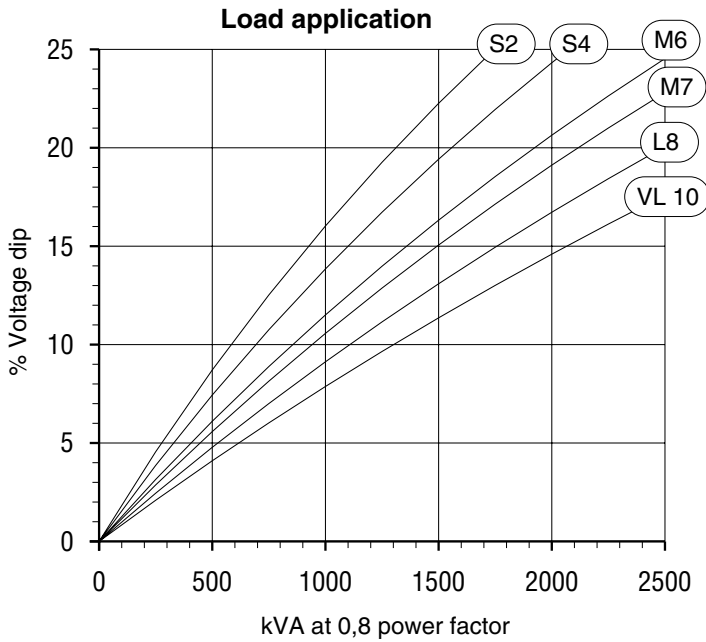

- 1) For a starting P.F. differing from 0,6 the starting kVA have to be multiplied by $(\text{Sine } \varnothing / 0,8)$
- 2) If voltage is not 400V(Y) , 230V(Δ) at 50 Hz then kVA must be multiplied by $(400/U)^2$ or $(230/U)^2$.

Products and materials shown in this catalogue may, at any time, be modified in order to follow the latest technological developments, improve the design or change the conditions of utilisation. Their description cannot in any case engage Leroy-Somer's liability. The values indicated are typical values .

ELECTRICAL DATA

Insulation class	H	Excitation system	A R E P + PMI
Winding pitch - Code	2/3 - (N° 6)	A.V.R. model	R 449
Leads	6	Voltage regulation (steady state)	± 0,5 %
Drip proof	IP 23	Sustained short-circuit current	300% (3 IN) : 10s
Altitude	≤ 1000 m	Total harmonic (*) TGH / THC	< 4 %
Overspeed	2250 min⁻¹	Waveform : NEMA = TIF - (*)	< 50
Air flow	1,6 m³/s	Waveform : I.E.C. = THF - (*)	< 2 %

(*) Total harmonic content line to line, at no load or full rated linear and balanced load

RATINGS : kVA / kW - Power factor = 0,8

Duty/Ambiant T°	Continuous / 40°C								Stand-by / 40°C				Stand-by / 27°C			
Class/T° rise	H / 125° K				F / 105° K				H / 150° K				H / 163° K			
Phase	3 ph.				3 ph.				3 ph.				3 ph.			
Y	380V	416V	440V	480V	380V	416V	440V	480V	380V	416V	440V	480V	380V	416V	440V	480V
Δ	240V				240V				240V				240V			

50.1 S2	kVA	865	946	1001	1092	778	852	901	983	908	994	1051	1147	951	1041	1100	1200
	kW	692	757	801	874	622	682	721	786	726	795	841	918	761	833	880	960
50.1 S4	kVA	974	1066	1128	1230	876	959	1015	1107	1022	1119	1184	1292	1071	1173	1240	1353
	kW	779	853	902	984	701	767	812	886	818	895	947	1034	857	938	992	1082
50.1 M6	kVA	1164	1274	1348	1470	1047	1147	1213	1323	1222	1338	1415	1544	1280	1401	1482	1617
	kW	931	1019	1078	1176	838	918	970	1058	978	1067	1132	1235	1024	1121	1186	1294
50.1 M7	kVA	1259	1378	1458	1590	1133	1240	1312	1431	1322	1447	1530	1670	1385	1516	1603	1750
	kW	1007	1102	1166	1272	906	992	1050	1145	1058	1154	1224	1336	1108	1213	1282	1400
50.1 L8	kVA	1354	1482	1568	1710	1218	1334	1411	1539	1421	1556	1646	1796	1489	1630	1724	1881
	kW	1083	1186	1254	1368	974	1067	1129	1231	1137	1245	1317	1437	1191	1304	1379	1505
50.1 VL10	kVA	1501	1643	1738	1900	1351	1479	1564	1706	1576	1725	1825	1991	1651	1808	1912	2086
	kW	1201	1314	1390	1520	1081	1183	1251	1365	1261	1380	1460	1593	1321	1446	1530	1669

EFFICIENCIES (%) - Class H / 40° C

	Three phase : 480 V									
	P.F. = 0,8					P.F. = 1				
	1/4	2/4	3/4	4/4	St.by	1/4	2/4	3/4	4/4	St.by
50.1 S2	92,3	94,6	94,7	94,4	94,1	92,9	95,5	96	96	96
50.1 S4	92,7	94,9	95,1	94,7	94,5	93,3	95,8	96,3	96,3	96,2
50.1 M6	93,3	95,3	95,5	95,2	95	93,8	96,1	96,6	96,6	96,5
50.1 M7	93,6	95,5	95,6	95,3	95,1	94,1	96,3	96,7	96,7	96,7
50.1 L8	93,7	95,7	95,9	95,6	95,5	94,2	96,4	96,9	96,9	96,9
50.1 VL10	93,9	95,8	96	95,8	95,7	94,4	96,5	97	97	97

REACTANCES (%) - TIME CONSTANTS (ms) - CLASS H / 480 V

		50.1 S2	50.1 S4	50.1 M6	50.1 M7	50.1 L8	50.1 VL10
Kcc	Short-circuit ratio	0,332	0,343	0,352	0,349	0,371	0,381
Xd	Direct axis synchronous reactance unsaturated	394	381	377	375	353	343
Xq	Quadrature axis synchronous reactance unsaturated	236	229	226	225	212	206
T'do	Open circuit time constant	2210	2350	2520	2600	2720	2830
X'd	Direct axis transient reactance saturated	29,6	28,2	27,3	26,8	24,6	23,2
T'd	Short circuit transient time constant	196	205	214	218	222	225
X''d	Direct axis subtransient reactance saturated	16,4	15,5	15	14,8	13,5	12,8
T''d	Subtransient time constant	16	17	18	19	20	21
X''q	Quadrature axis subtransient reactance saturated	20,5	19,5	18,8	18,5	16,9	16
Xo	Zero sequence reactance unsaturated	3,9	3,7	3,5	3,5	3,2	3,0
X2	Negative sequence reactance saturated	18,4	17,5	16,9	16,5	15,2	14,3
Ta	Armature time constant	33	36	39	41	41	42

OTHER DATA - CLASS H / 480 V

io (A)	No load excitation current	1,05	1,05	1,1	1,1	1,3	1,3
ic (A)	Full load excitation current	5	4,85	4,9	4,9	5	5
uc (V)	Full load excitation voltage	63	61	62	62	63	63
ms	Recovery time(ΔU = 20 % transient)	< 500	< 500	< 500	< 500	< 500	< 500
kVA	Motor start. (ΔU = 20% sust.) or (ΔU = 50% Transient)	2180	2400	3000	3180	3420	3780
%	Transient dip (rated step load) - PF : 0,8 LAG	15	14	13,5	13	12,5	12
W	No load losses	15572	16496	17849	18529	19756	21144
W	Heat rejection	51728	55070	59294	62732	62962	66638

According to : I.E.C. 34.1/34.2 - U.T.E. : NF C 51.111 - V.D.E. 0530 - B.S. 4999 & 5000 - NEMA : MG 1.22 - ISO 8528 . 3 - CSA (C 22.2 + UL 2200).
Products and materials shown in this catalogue may, at any time, be modified in order to follow the latest technological developments, improve the design or change the conditions of utilisation. Their description cannot in any case engage Leroy-Somer's liability. The values indicated are typical values .

TRANSIENT VOLTAGE VARIATION - 480 V

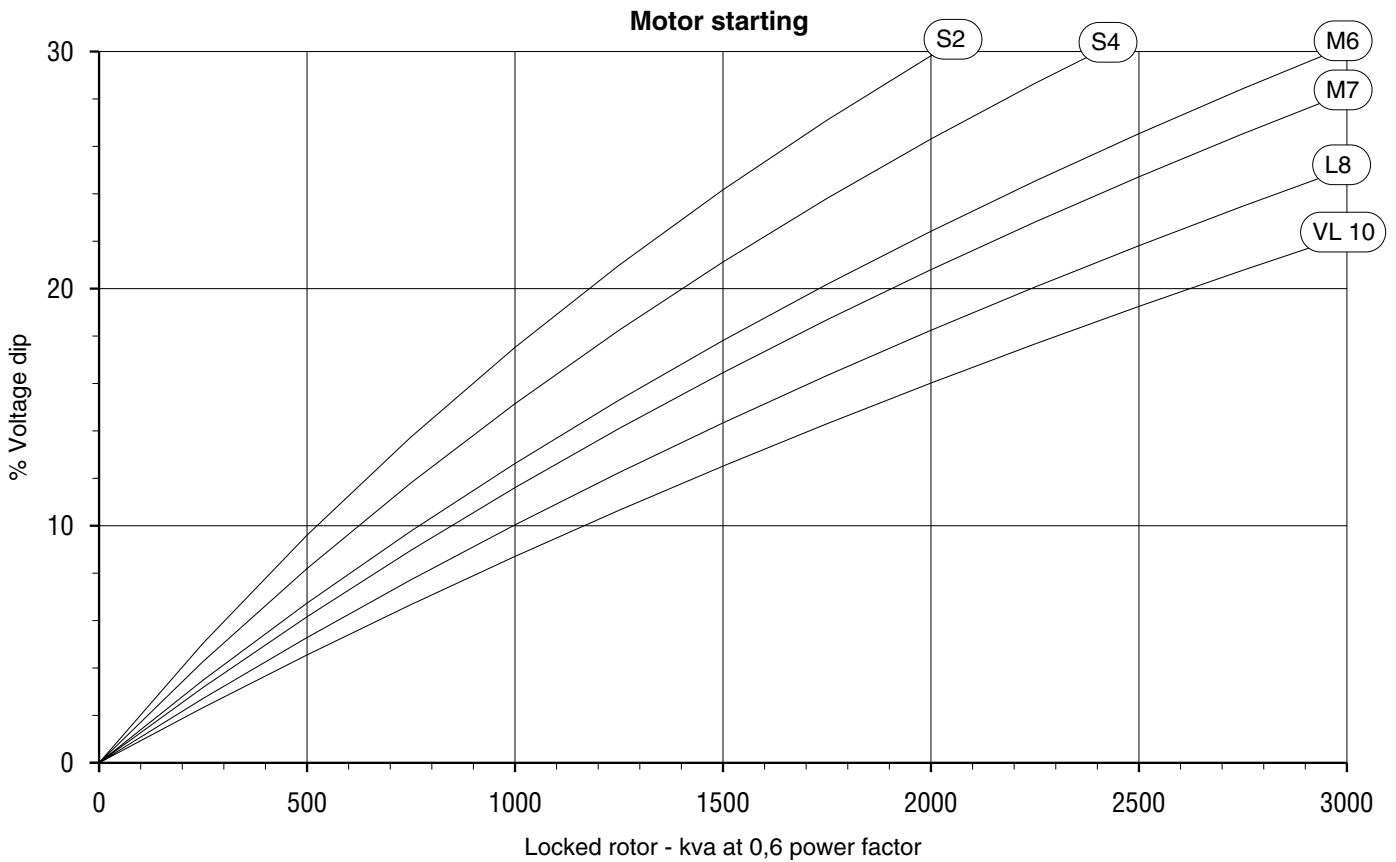
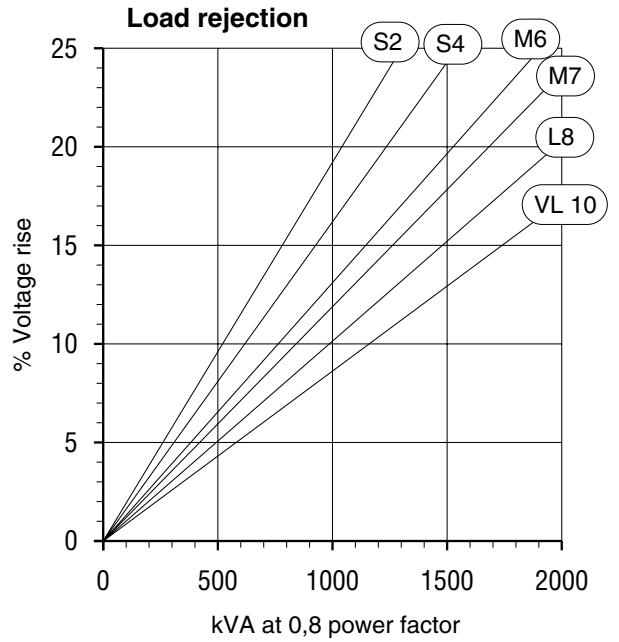
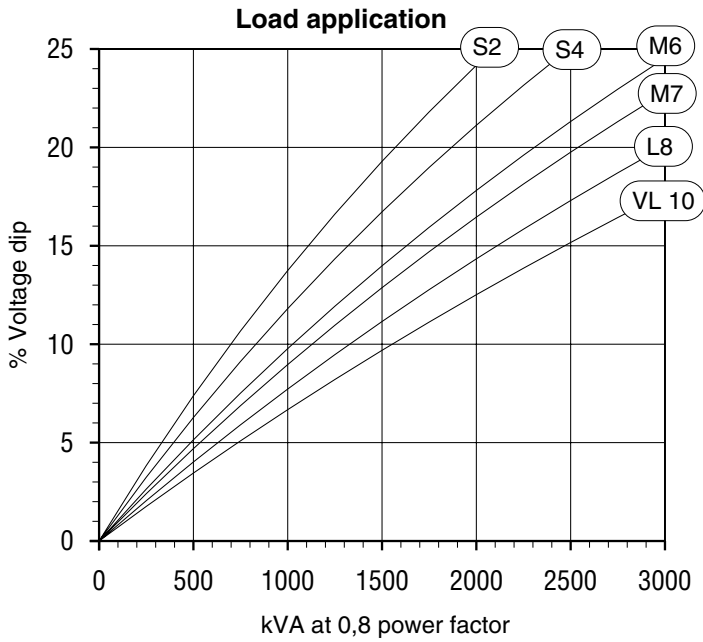

- 1) For a starting P.F. differing from 0,6 the starting kVA have to be multiplied by $(\text{Sine } \varnothing / 0,6)$
- 2) If voltage is not 480V(Y), 277V(Δ), 240V(Υ) at 60 Hz then kVA must be multiplied by $(480/U)^2$ or $(277/U)^2$ or $(240/U)^2$.

Products and materials shown in this catalogue may, at any time, be modified in order to follow the latest technological developments, improve the design or change the conditions of utilisation. Their description cannot in any case engage Leroy-Somer's liability. The values indicated are typical values .

DIMENSIONS

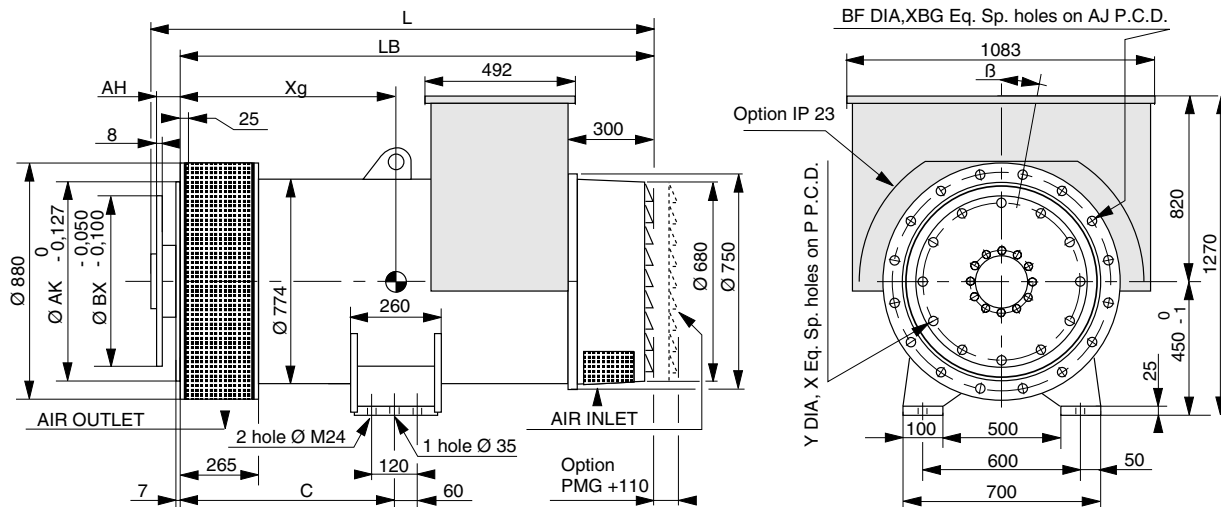

FRAME DIMENSIONS (mm)							Mass (kg)	COUPLING		
TYPE	L maxi without PMG	LB SAE 00	LB SAE 0	C SAE 00	C SAE 0	Xg	M	Flange	SAE	SAE
LSA 50.1 S2	1551	1485	1510	800	825	630	1960	Flex plate	00	0
LSA 50.1 S4	1551	1485	1510	800	825	645	2150	SAE 24	•	
LSA 50.1 M6	1641	1575	1600	800	825	686	2420	SAE 21	•	
LSA 50.1 M7	1641	1575	1600	800	825	700	2580	SAE 18	•	•
LSA 50.1 L8	1736	1670	1695	800	825	744	2860			
LSA 50.1 VL10	1831	1765	1790	800	825	789	3160			

FLANGE DIMENSIONS (mm)						FLEX PLATE DIMENSIONS (mm)					
S.A.E.	AK	AJ	XBG	BF	β	S.A.E.	BX	P	X	Y	AH
00	787,4	850,9	16	14	11° 15'	18	571,5	542,9	6	18	15,8
0	647,7	679,5	16	14	11° 15'	21	673,1	641,3	12	18	0
						24	733,4	692,1	12	21	0

TORSIONAL ANALYSIS DATA

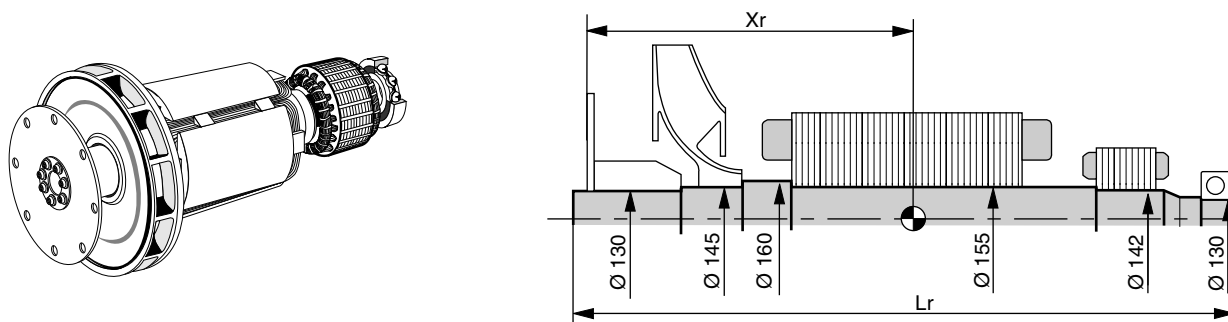

TYPE	Flex plate S.A.E. 0 - 18				Flex plate S.A.E. 00 - 18				Flex plate S.A.E. 00 - 21			
	Xr	Lr	M	J	Xr	Lr	M	J	Xr	Lr	M	J
LSA 50.1 S2	617	1380	706	14,4	596	1380	701	14,4	578	1380	705	14,9
LSA 50.1 S4	637	1380	767	16,1	616	1380	762	16,1	598	1380	766	16,6
LSA 50.1 M6	680	1470	862	18,5	659	1470	857	18,5	641	1470	861	19
LSA 50.1 M7	691	1470	913	20	670	1470	908	20	652	1470	912	20,5
LSA 50.1 L8	742	1565	1008	22,5	720	1565	1003	22,5	702	1565	1007	23
LSA 50.1 VL10	788	1660	1114	25,1	769	1660	1106	25,1	749	1660	1113	25,6

Products and materials shown in this catalogue may, at any time, be modified in order to follow the latest technological developments, improve the design or change the conditions of utilisation. Their description cannot in any case engage Leroy-Somer's liability. The values indicated are typical values.

DIMENSIONS

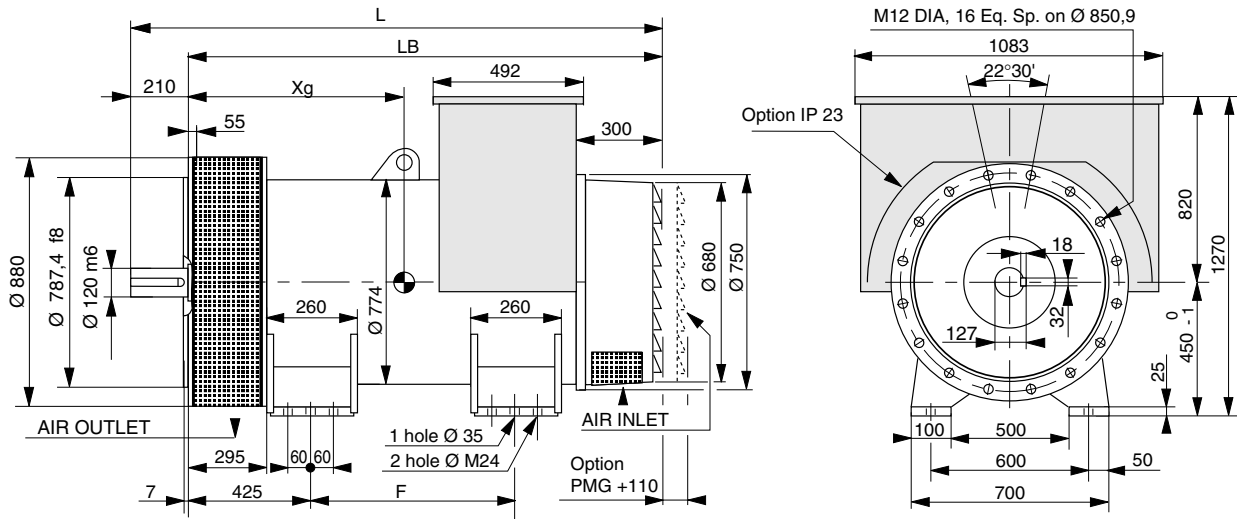

FRAME DIMENSIONS (mm)

TYPE	L max without PMG	LB	F	Xg	Mass (kg)
LSA 50.1 S2	1725	1515	595	636	2060
LSA 50.1 S4	1725	1515	595	653	2250
LSA 50.1 M6	1815	1605	685	695	2522
LSA 50.1 M7	1815	1605	685	711	2770
LSA 50.1 L8	1910	1700	780	750	2955
LSA 50.1 VL10	2005	1795	875	801	3251

TORSIONAL ANALYSIS DATA

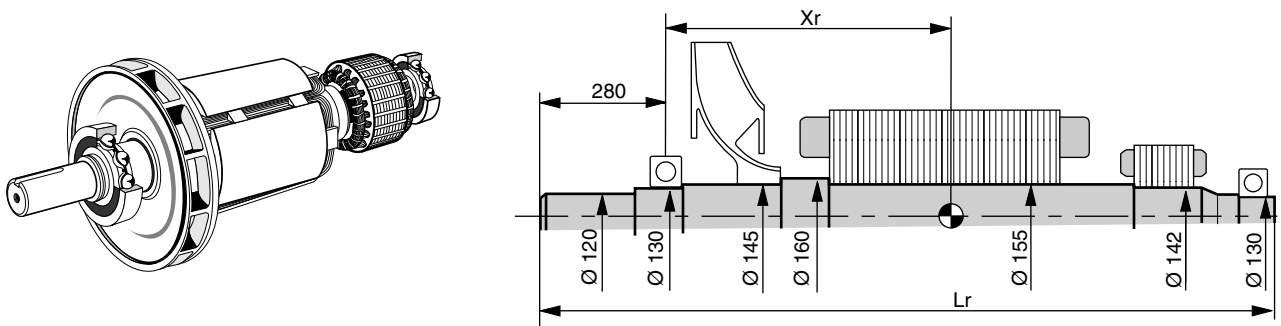

CENTRE OF GRAVITY : Xr (mm) - ROTOR LENGTH : Lr (mm) - MASS : M (kg) - MOMENTS OF INERTIA : J (kgm²) : (4J = MD²)

TYPE	Xr	Lr	M	J
LSA 50.1 S2	840	1579	670	13,4
LSA 50.1 S4	860	1579	731	15,1
LSA 50.1 M6	901	1669	827	17,6
LSA 50.1 M7	918	1669	878	19,1
LSA 50.1 L8	961	1764	973	21,5
LSA 50.1 VL10	1008	1859	1079	24,2

Products and materials shown in this catalogue may, at any time, be modified in order to follow the latest technological developments, improve the design or change the conditions of utilisation. Their description cannot in any case engage Leroy-Somer's liability. The values indicated are typical values .



MOTEURS LEROY-SOMER 16015 ANGOULÊME CEDEX - FRANCE

<http://www.leroy-somer.com>