

M40FA640A/A - Mark I

User Manual

Automatic Voltage Regulator for Three-phase Synchronous Generators

(Issued: 04.2010)



SIN.NT.015.6

Instruction Manual

Installation • Operation • Maintenance



MARELLI AVR M40FA640A

INTRODUCTION

This Technical Note provides general installation and operating information exclusively concerning the Marelli Motori regulator code specified in the document, mounted on the Marelli Motori synchronous generators specified in the next paragraph "APPLICATION".

Before the generator start and any types of regulation operation, read carefully and completely this Technical Note.

IMPORTANT NOTE: It is not the intention of this document to cover all the installation or connection diagram variations, nor does this manual provide information for every possible contingency. The connection drawings provided with the generator, the generator user manual and all the technical information provided by Marelli Motori Technical Personnel can integrate this Note.

In particular, the connection drawings into this document are provided only for explanation purposes. They do not cover all the application cases and not substitute the connection drawings usually provided with the generator.

Should further information be required, please contact After Sales Department (see the reference at the end of the page).

SAFETY PRECAUTIONS



WARNING: when the regulation device is energized (generator running), a lethal voltage is present at the top panel (connection side) and at all the parts electrically connected to it. Furthermore, there are components into the card that can reach high working temperatures, with high danger for the user in case of direct contact.



Every wiring and/or mechanical installation operation on the regulator must be performed only in generator stop conditions, and only by skilled personnel. Furthermore, pay attention to wait a time interval sufficient for the device cooling-down.



Every regulation setting operation must be performed with generator running in no load conditions, by skilled personnel, using tools suitable to assure the user safety (i.e. isolated screwdriver, protection glasses and gloves).

Marelli Motori is under no liability for any damages which may occur to the AVR, the plant or the persons, or for lost earnings, or financial loss, or system stoppages, due to missed out Technical Note reading (both safety and installation/operating instructions).



AFTER MARKET DEPARTMENT
MARELLI MOTORI S.p.A.
Tel: +39 0444 479775 Fax: +39 0444 479757
E-mail: service@marellimotori.com
Web: www.marellimotori.com

APPLICATION

The voltage regulator type "MARK I", is suitable for Synchronous Generators of MARELLI MOTORI make, MJB series, size range 160-500 frames. This regulator is proper to operate on machines rated from 10 up to 2000 kVA. The regulator is fully insulated in order to maintain high reliability also with severe ambient conditions (high level of humidity, dust, salt atmosphere), and in case of high vibrations level. The regulator is proper both for single and 3-phase operation.

DATI TECNICI - TECHNICAL DATA

REGULATION ACCURACY	±0.5%	a regime, per valori di tensione e carico nominali steady state conditions, for rated Voltage and PF
VOLTAGE DRIFT:	±0.5%	variazione di tensione per variazione T _{amb} 50°C of voltage change for 50°C T _{amb} change
RESPONSE TIME:	1 cycle	(20ms-16.6ms)
OPERATING TEMPERATURE:	-30°C ÷ +70°C	
EXCITER FIELD RESISTANCE:	3.5Ω (min) ÷ 20Ω (max)	
INPUT/OUTPUT DATA:		
-SUPPLY VOLTAGE:	170 - 277V (50/60Hz)	
-		
-POWER SUPPLY:	1000 VA (max)	
-		
-POWER DISSIPATED:	30 W (max)	
-		
-VOLTAGE SENSING:	170 - 270 / 380 - 415 / 440 - 480 V	
-	(Three or Single Phase Sensing)	
-OUTPUT VOLTAGE (DC):	80V	(max, servizio continuo)
-		
-OUTPUT CURRENT (DC):	8A	(max, servizio continuo)
-		(max, continuous)
-OUTPUT CURRENT (DC):	15 A	(max, in forzamento 1 minuto)
-		(max 1 minute forcing)

**VOLTAGE REGULATOR
M40FA640A/A
MARK I**

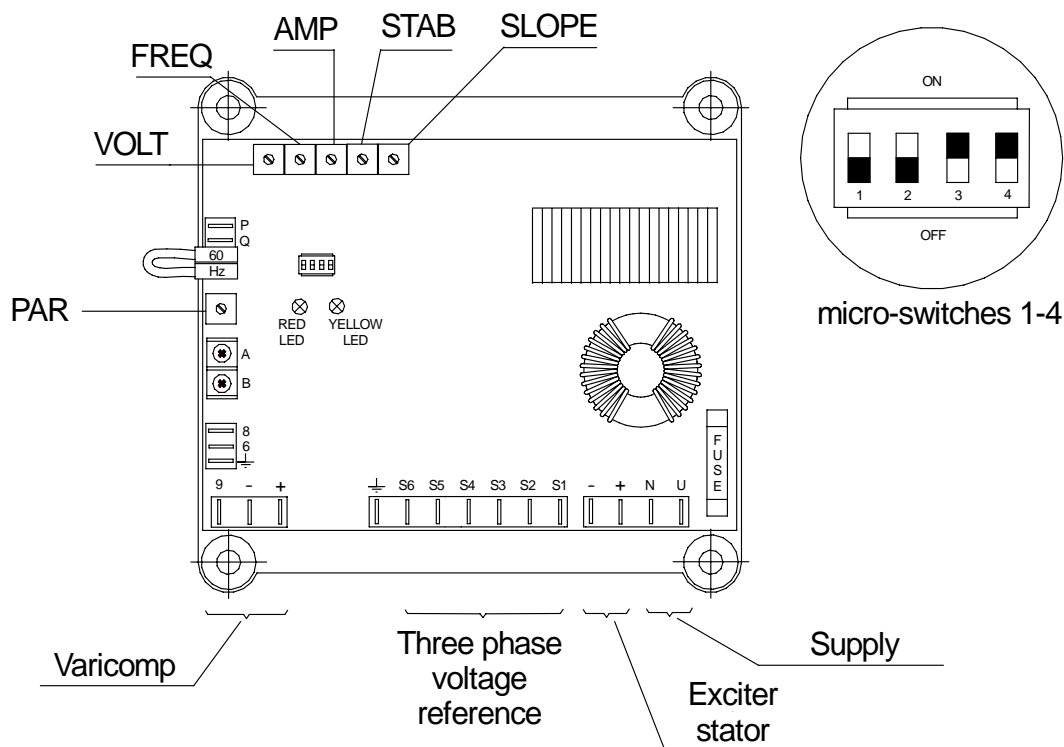

TERMINALS

Connection terminals are performed through FAST-ON terminals. The terminals have to be connected according the applicable wiring diagram, in order to avoid any possible mistake in the wiring. The use of FAST-ON terminals makes any operation on regulator (as replacement, connection to accessories, setting up) extremely simple.

POWER STAGE INPUT TERMINALS

“U”, “N” : terminals for power supply

VOLTAGE SENSING INPUT TERMINALS

“S1 - S2”, “S3 - S4”, “S5 - S6” are the terminals for three phase or single phase voltage sensing.

POWER OUTPUT TERMINALS

“+”, “-”: output terminals (positive, DC, and negative, DC).

CONTROL TERMINALS

“HZ”, “60” : terminals for changing the low speed protection terminals

“P”, “Q” : terminals for connection of external trimmer (100kOhm).

“6”, “8”: input terminals for connections of external control systems (input for D.C. voltage , +/-3 Vdc). The terminal “ ” is to be used only in case of special connections.



TERMINALS for interconnecting with over-boosting excitation systems

“+”, “-” : output terminals (positive, DC, and negative, DC)

“G” : voltage sensing

EXTERNAL POTENTIOMETER

At the terminals “P” and “Q” an external trimmer (minimum rating 500mW, resistance about 100kOhm) can be connected. By acting on such trimmer, it is possible to obtain a voltage regulation of about +/- 5 % around the nominal voltage. By using a 200kOhm potentiometer it is possible to obtain a voltage regulation of about +/- 10 %. The trimmer is connected anyway (through the regulator) to the output of the generator and then it represents a live part.

UNDERFREQUENCY LIMITER

The regulator is provided with internal circuits in order to reduce the excitation, when running at low speed, in order to avoid damages to the excitation system of the generator (i.e. to the regulator, to the exciter field, to the rotating rectifier, main rotor).

The potentiometer “FREQ” fixes the corner-frequency, that is the frequency at which the limiter operates. Below that particular frequency, red LED switches-on and the voltage of the generator reduces further with speed reduction.

By setting the micro-switch nr. 4 in OFF position, the voltage reduction is smaller and is close to be proportional to the speed reduction (voltage reduction is settable by the potentiometer “SLOPE”).

ANALOGUE INPUT

The AVR accepts a voltage analogue input of +/-3Vdc maximum, to control the exciter field of the generator.

This input has to be applied to terminals 6 and 8.

In case of single operation, a maximum change of +/-3Vdc of the analogue input leads to a maximum change of +/- 25% of the generator voltage, with respect to the rated generator voltage.

A value of 0Vdc does not lead to any change in excitation.

The analogue input is usually used for the voltage regulator control by means of the Marelli power factor regulator, for parallel operation with the grid.

This input can be also connected to external devices not made by Marelli, for remote control of the generator voltage or the excitation during parallel operations (voltage matching and power factor regulation), as long as those devices were equipped with suitable outputs (insulated outputs, and voltage range not higher than $\pm 3V_{dc}$).

WARNING: in the case of parallel with the grid, and voltage regulator controlled by an external device by means of the analogue input, **pay attention to the analogue input voltage value after the load rejection.**

In this particular case, in order to avoid any dangerous generator over-voltages, the voltage value between the terminals 6 and 8 must be reduced to 0Vdc or to any values leading to a generator voltage not exceeding the rated + 5%.

STABILITY SETTING

The voltage regulator is provided with internal adjustable stability circuits in order to allow operation in a wide range of applications.

The stability of the regulator can be set on field to adapt it to the characteristics of the plant and/or the driving engine (diesel engine, water turbine, gas turbine) in order to obtain the best voltage response.

To change the stability characteristics of the regulator, it is necessary to act on the potentiometer "STAB" (for fine setting of stability).

An additional coarse setting of stability can be achieved by means of the micro-switches number 1 e 2.

DROOP KIT DEVICE

The device is included in the voltage regulator, to allow parallel operation between similar generators: the device permits to share correctly the total reactive power required by the load among all generators operating in parallel.

The device is composed by an external current transformer (which senses the current in phase "W") and the internal "droop" circuit of the regulator. The C.T. is placed on phase "W"; the phases "U" and "V" have to be connected to terminals "S1" and "S2".

The voltage regulator is provided with input terminals (terminals "A" and "B") for easy connection to an external current transformer. Such terminals are normally shorted by a connection bridge, when the generator is used in single operation.

If the voltage is increasing as the load increases, it is necessary to reverse the leads of the current transformer at the terminals A-B.

OVER-EXCITATION LIMITER

This function permits to limit the over-excitation due to particular load conditions that could cause the generator damage.

As soon as the excitation voltage rises over a certain threshold, set by means of the potentiometer AMP, for a time larger than the limiter time delay, the over-excitation limiter steps-down the excitation voltage to the threshold value.

Limiter time delay depends on the amount of the over-load: more the over-load arisen, quicker the limiter action.

Limiting the excitation voltage, the generator excitation level decreases, partially or totally, depending on the over-load occurred. In case of excitation shutdown due to the limiter, the de-excitation condition could be not maintained.

WARNING: Even if correctly set, this device does not substitute external systems protections, it is only a completing device.

WARNING: in case of generator paralleled with the grid, an over-excitation condition detected by the limiter can lead to a generator excitation shutdown, with risk of loss of synchronism.

LIMITER SETTING:

for a quicker limiter setting, it is possible to momentarily disable the time delay, by means of the micro-switch 3 (see also the next paragraphs).

In order to properly set the limiter, please apply the following procedure:

- when the generator is running at the rated speed, apply the maximum desired load;
- select position OFF for the micro-switch 3;
- carefully rotate counter-clockwise the potentiometer AMP, until the yellow LED lights up and the generator voltage decreases to a stable value, lower than the rated voltage;
- carefully rotate clockwise AMP until the yellow LED switches-off; the generator voltage must recover the rated value;
- select position ON for the micro-switch 3.

If the procedure is properly carried out, the excitation voltage threshold is set to a value 15-20% higher than the excitation voltage at the maximum desired load, previously applied.

Time delay depends on the amount of the over-load occurred: it can range from 10s minimum to some minutes maximum.

USE OF POTENTIOMETERS

VOLT - potentiometer to change the output voltage of the generator:

Normally the internal potentiometer VOLT allows possibility of adjusting the voltage in a wide range (i.e. between 200 and 560 V); to obtain a finer possibility of voltage setting or to adjust the voltage from the control panel, or in order to limit the voltage range, an external potentiometer can be connected to the terminal "P" and "Q" (resistance about 100kOhm, 500mW, to obtain +/- 5% voltage regulation).

 ⇒ increases voltage

FREQ - potentiometer to change the low speed protection:

usually it is set at the factory in order to reduce the excitation when speed becomes lower than 90% of rated speed at 50 Hz. By removing the bridge which normally shorts the terminals "Hz" and "60", the speed protection acts properly for 60 Hz operation.

By acting on potentiometer FREQ it is possible to adjust further (in case should it be necessary) the frequency at which the low-speed protection is effective.

 ⇒ decreases frequency of intervention

AMP - potentiometer to change the over-excitation limiter:

it permits to set the excitation voltage threshold of the over-excitation limiter.

The default setting of this potentiometer is at the maximum excitation voltage threshold.

 ⇒ increases the over excitation threshold.

STAB - potentiometer to change stability:

by rotating it clockwise stability increases, but response time becomes larger.

 ⇒ increases response time, increases stability

SLOPE - potentiometer to change the low speed protection characteristic slope:

with the micro-switch 4 OFF, this potentiometer allows to increase or decrease the under speed ramp slope, and set the voltage droop for a fixed reduced speed.

 ⇒ decreases the voltage droop for a fixed frequency intervention.

PAR - potentiometer to change the droop

This potentiometer allows to change the voltage droop in load conditions.

 ⇒ the droop increases

USE OF MICROSWITCHES

To change the stability characteristics of the regulator, it is possible to use the micro-switches.
In such a way it is possible obtain changes in the transient response of the regulator.

Micro-switch 1 <input checked="" type="checkbox"/> ON <input type="checkbox"/>	Transient response becomes faster
Micro-switch 2 <input checked="" type="checkbox"/> ON <input type="checkbox"/>	Transient response becomes faster
Micro-switch 3 <input checked="" type="checkbox"/> ON <input type="checkbox"/> OFF	Solo per taratura rapida limitazione di sovraeccitazione: toglie il tempo di intervento della limitaz. Only for quick setting of the excitation limiter: it permits to disable the normal limiter time delay
Micro-switch 4 <input checked="" type="checkbox"/> ON <input type="checkbox"/> OFF	Protezione bassa frequenza con pendenza V/f tarabile (fare anche riferimento al potenz. "SLOPE") Low speed protection with V/f slope adjustment (see "SLOPE" potentiometer)

FUSE

The voltage regulator is provided with an internal protecting fuse (which acts in case of faults on the regulator or very large overloads on exciter circuit).

EMI SUPPRESSOR

The AVR is provided with an internal Electromagnetic Interference filter: this interference suppression system permits to obtain compliance with relevant EMC standards on MARELLI MOTORI generators.

12 TERMINALS + AUX. WINDING

PER IL FUNZIONAMENTO A 60 Hz TOGLIERE IL PONTE 60-Hz
 FOR 60 Hz OPERATION OPEN THE BRIDGE 60-Hz

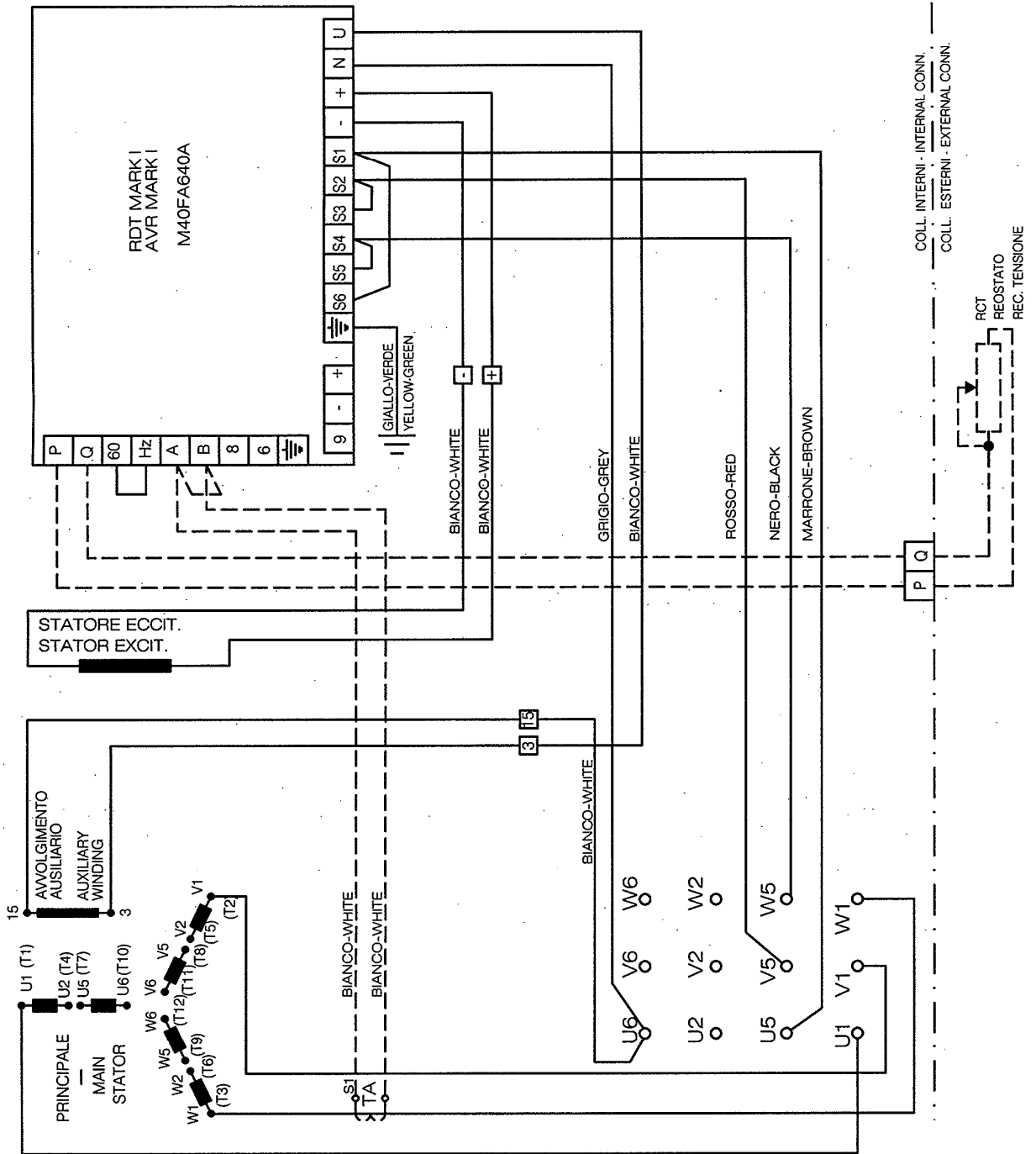

12 TERMINALS + OVER EXCITATION DEVICE

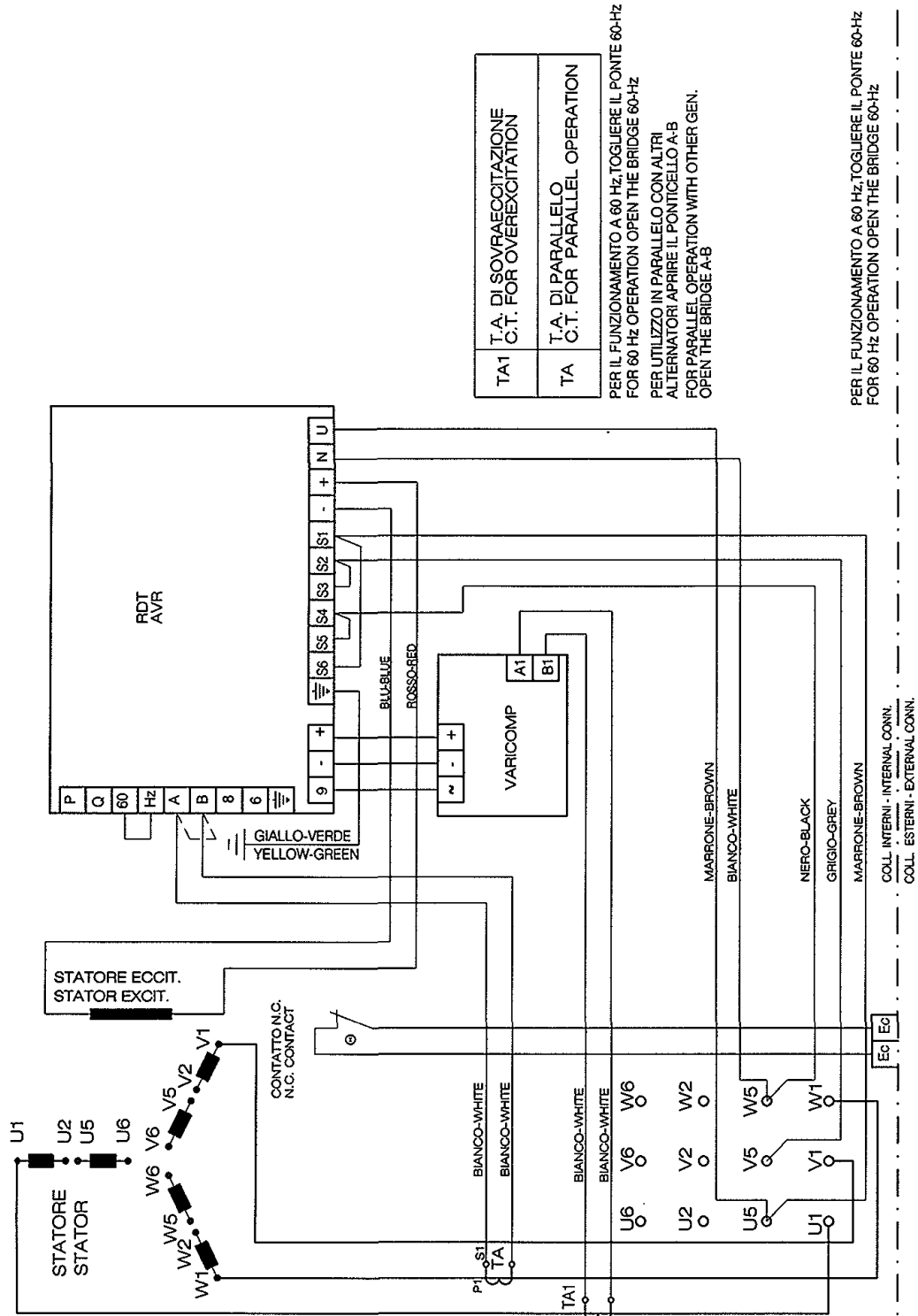

TA1	T.A. DI SOVRAECCITAZIONE C.T. FOR OVEREXCITATION
TA	T.A. DI PARALLELO C.T. FOR PARALLEL OPERATION

PER IL FUNZIONAMENTO A 60 Hz TOGLIERE IL PONTE 60-Hz
 FOR 60 Hz OPERATION OPEN THE BRIDGE 60-Hz
 PER UTILIZZO IN PARALLELO CON ALTRI
 ALTERNATORI APRIRE IL PONTICELLO A-B
 FOR PARALLEL OPERATION WITH OTHER GEN.
 OPEN THE BRIDGE A-B

PER IL FUNZIONAMENTO A 60 Hz TOGLIERE IL PONTE 60-Hz
 FOR 60 Hz OPERATION OPEN THE BRIDGE 60-Hz

6 TERMINALS + OVER EXCITATION DEVICE

PER IL FUNZIONAMENTO A 60 Hz, TOGLIERE IL PONTICELLO TRA I MORSETTI 60-Hz DEL R.D.T.
 FOR 60 Hz OPERATION, THE BRIDGE BETWEEN 60-Hz TERMINALS OF A.V.R. HAVE TO BE REMOVED
 PER UTILIZZO IN PARALLELO CON ALTRI ALTERNATORI APRIRE IL PONTICELLO A-B
 FOR PARALLEL OPERATION WITH OTHER GEN. OPEN THE BRIDGE A-B

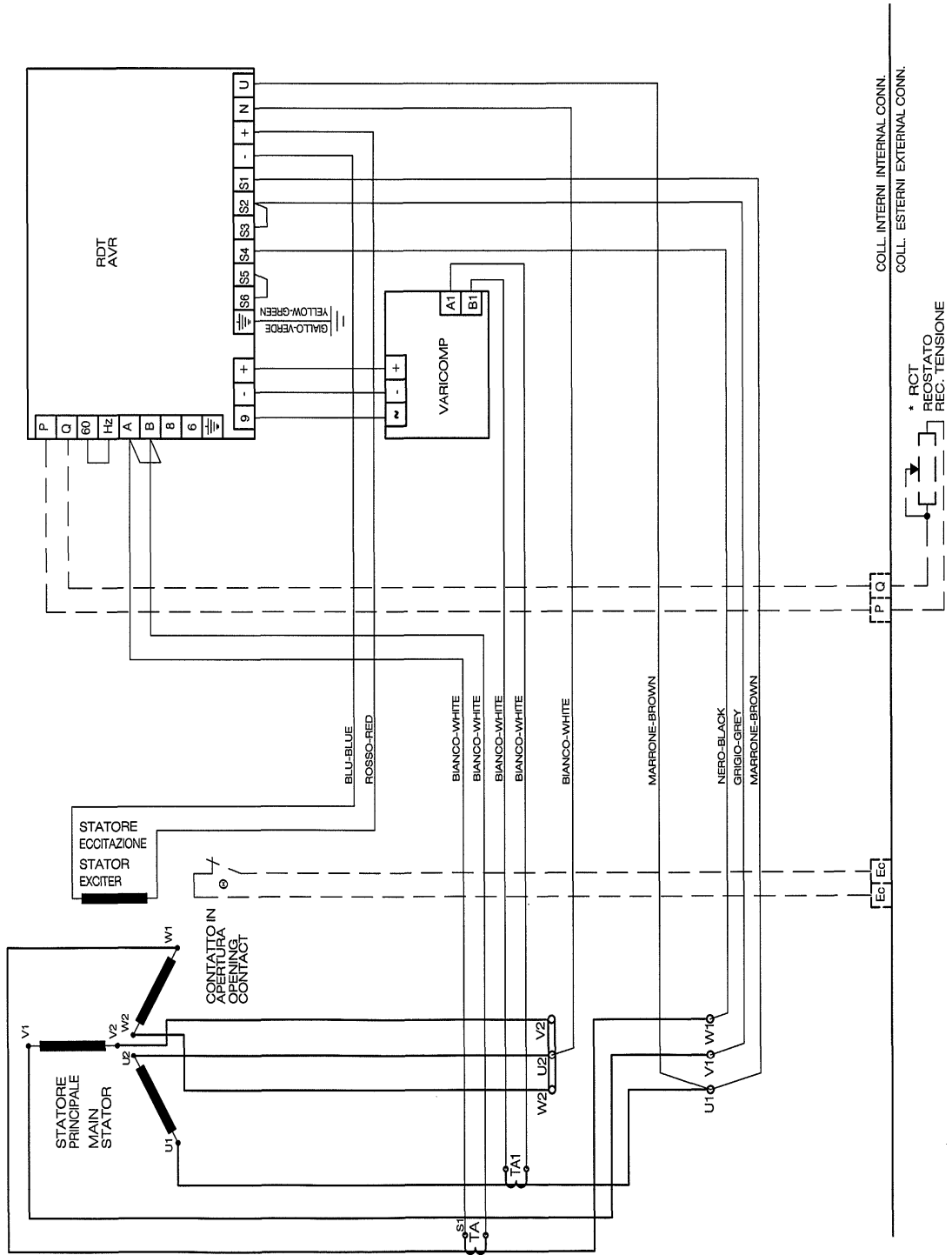

6 TERMINALS + AUX. WINDING

PER IL FUNZIONAMENTO A 60 HZ, TOGLIERE IL PONTICELLO TRA I MORSETTI 60-HZ DEL R.D.T. PER 60 HZ OPERATION, THE BRIDGE BETWEEN 60-HZ TERMINALS OF A.V.R. HAVE TO BE REMOVED. PER UTILIZZO IN PARALLELO CON ALTRI ALTERNATORI APRIRE IL PONTICELLO A-B. FOR PARALLEL OPERATION WITH OTHER GEN OPEN THE BRIDGE A-B.

