

R120

A.V.R.
Installation and maintenance

LEROY-SOMER™

Nidec
All for dreams

R120

A.V.R.

This manual concerns the alternator A.V.R. which you have just purchased. We wish to draw your attention to the contents of this maintenance manual.

SAFETY MEASURES

Before using your machine for the first time, it is important to read the whole of this installation and maintenance manual.

All necessary operations and interventions on this machine must be performed by a qualified technician.

Our technical support service will be pleased to provide any additional information you may require.

The various operations described in this manual are accompanied by recommendations or symbols to alert the user to potential risks of accidents. It is vital that you understand and take notice of the following warning symbols.

WARNING

Warning symbol for an operation capable of damaging or destroying the machine or surrounding equipment.



Warning symbol for general danger to personnel.



Warning symbol for electrical danger to personnel.



All servicing or repair operations performed on the AVR should be undertaken by personnel trained in the commissioning, servicing and maintenance of electrical and mechanical components.



When the generator is driven at a frequency less than 28 Hz for more than 30 seconds with an analogic regulator, the AC power must be disconnected.

WARNING

This A.V.R. can be incorporated in a machine marked C.E.

This manual is be given to the end user.

© - We reserve the right to modify the characteristics of its products at any time in order to incorporate the latest technological developments. The information contained in this document may therefore be changed without notice.

This document may not be reproduced in any form without prior authorization.

All brands and models have been registered and patents applied for.

R120

A.V.R.

CONTENTS

1 - GENERAL DESCRIPTION	4
2 - OPERATION OF THE A.V.R.	4
3 - TECHNICAL SPECIFICATION	5
4 - MAIN FUNCTION OF THE A.V.R.	6
5 - A.V.R. ADJUSTMENTS	7
5.1 - V-TRIM (V).....	7
5.2 - FRO (UF)	7
5.3 - STAB (S)	7
6 - A.V.R. CONTROLS	7
7 - TROUBLE SHOOTING CHART	8
8 - MULTIMETER CHECKS	9
9 - STATIC TEST PROCEDURE	10
10 - DIMENSIONS	12
11 - SPARE PARTS	13
11.1 - Designation	13
11.2 - Technical support service	13
Disposal and recycling instructions	

R120

A.V.R.

1 - GENERAL DESCRIPTION

The Automatic voltage regulator (AVR) is a compact, high performance encapsulated unit. The AVR incorporates latest technology and efficient semiconductor to achieve a high degree of miniaturization when applied to 3 phase and 1 phase AC brushless generator within its input and output limits, the unit offers excellent reliability.

The AVR supplies DC excitation to the exciter field of a brushless generator to keep the terminal voltage within close limits from NO-LOAD to FULL LOAD.

The recovery time on sudden loading is likely to be around 0.5 sec. to recover 98% of the rated voltage. Please note that the transient performance like voltage dip and recovery time are mainly decided by the generator and exciter design parameters. Best performance from the regulator can be obtained by keeping full load excitation around 60V DC.

The generator employs true average sensing circuit, dV/dt snubber and special filters circuits to cope with NON-LINEAR loading like battery charger, DC drives etc.

The voltage regulation is guaranteed only for linear loading. Severely distorting NON-LINEAR loads can cause regulation problem.

AVR is tested prior to dispatch through a quality plan, for standard voltage and frequency.

Soft start circuitry is included which provides a smooth control on build up of generator output voltage.

A frequency roll off circuit continually monitors the generator, under speed protection by reducing the generator output voltage proportionally with speed below a threshold.

2 - OPERATION OF THE A.V.R.

The AVR derives its power supply from the line to neutral terminal of the AC Generator, at level of 240V AC rms at 50Hz or 60Hz. The sensing voltage, which is the regulated voltage, is derived from line to line (for 3 phase) and line to neutral (for 1 phase). The AVR forms an important part of the close loop system comprising of the generator field, generator armature and the AVR.

The AVR first builds up the generator voltage from its residual levels, to the rated value of 415V for 3 phase and 240V for 1phase. When the generator is loaded, the sensed voltage goes down and generates the error voltage, which is required to drive the closed loop system.

The AVR contains high gain amplifier, ramp and pedestal circuitry. Depending upon the value of the amplifier voltage (either high or low) the ramp intersects the amplified voltage at a point, which is early or late in the half cycle. At the intersection point a firing pulse is produced to trigger the power device.

When the power device is triggered early in the half cycle, more voltage is let into the field and when triggered late in the half cycle, less voltage is let in to the field.

In order to reduce the generator voltage at lower speed, a signal inversely proportional to the speed is fed as an extra input. At higher speeds the voltage reduces more than proportional with the speed.

R120

A.V.R.

3 - TECHNICAL SPECIFICATION

1) Sensing input

- Voltage: 277 V AC $\pm 10\%$ for 1 phase, 415 V AC $\pm 10\%$ for 3 phase, 2 line sensing AVR Senses true average of the line to line waveform. Use Resistor (SMD) network for trouble free sensing & control of sensed voltage / regulation.

2) Input power

- Voltage: 277V AC r m s $\pm 10\%$
- Frequency: 50/60 Hz

3) Output power

- Voltage: 95 V DC at 240V AC Input
- Current:
• 4 Amps DC Continuous
• 6 Amps for 30sec. (when allowed by field resistance)

4) Operating temperature: -20°C to $+70^{\circ}\text{C}$

5) Storage temperature: -40°C to $+80^{\circ}\text{C}$

6) Voltage adjustment: min $\pm 10\%$ of rated voltage.

7) Stability adjustment: adjustable to get Steady state Stability good transient response.

8) Under frequency roll - off adjustment: available below 46 Hz for 50 Hz & below 56 Hz for 60 Hz.

9) Voltage Build up: 2 Volts (L-N)

10) Voltage regulation: $\pm 1\%$ at AVR terminals with a TGH $< 5\%$.

11) Thermal drift: $\pm 1\%$ for 30°C change in temperature.

12) Response time: less than 50 milli seconds.

13) Closed loop response: typically 0.5sec to recover to 98% of the set voltage for a field forcing ratio of 1:2.

14) Sense Loss protection: voltage should collapse, when the sensing circuit is open.

15) Over excitation protection: 10V DC to 85V DC.

Set point : 60 V DC

16) Fuse for protection: 4 Amps, 240 Volts AC.

17) All potentiometers: multi-turn

18) Sealing of Potentiometers: except V – trim pot all pots are sealed.

19) Frequency roll off indicator: LED provided (UF).

20) Sense Loss indicator: LED provided (SL).

21) Over excitation indicator: LED provided (OE).

22) Protection on the devices: Suitable R-C Snubber to be provided for the device used to protect this from surge.

23) Potting/ Encapsulation Details: the components on the AVR should be completely encapsulated with suitable PU resin compound to absorb transients / vibrations while in operation.

24) Excitation details of alternator: (typical)

- Full load:

- Excitation Voltage: 40 to 50 Volts
- Excitation Current: 2.5 to 4.0 Amps

25) Terminal marking: refer drawing

26) Dimension:

- Overall: 104 x 94 x 40 (in mm)
- Mounting: 83 (in mm)
- Mounting hole dia: 5.5 (in mm)

27) Weight: 185 Gms

R120 A.V.R.

4 - MAIN FUNCTION OF THE A.V.R.

The AVR derives its power supply from line to neutral terminals of the ac generator at a level of 240V AC at 50/60Hz. The sensing voltage which is regulated is derived from the line to line terminals of the generator.

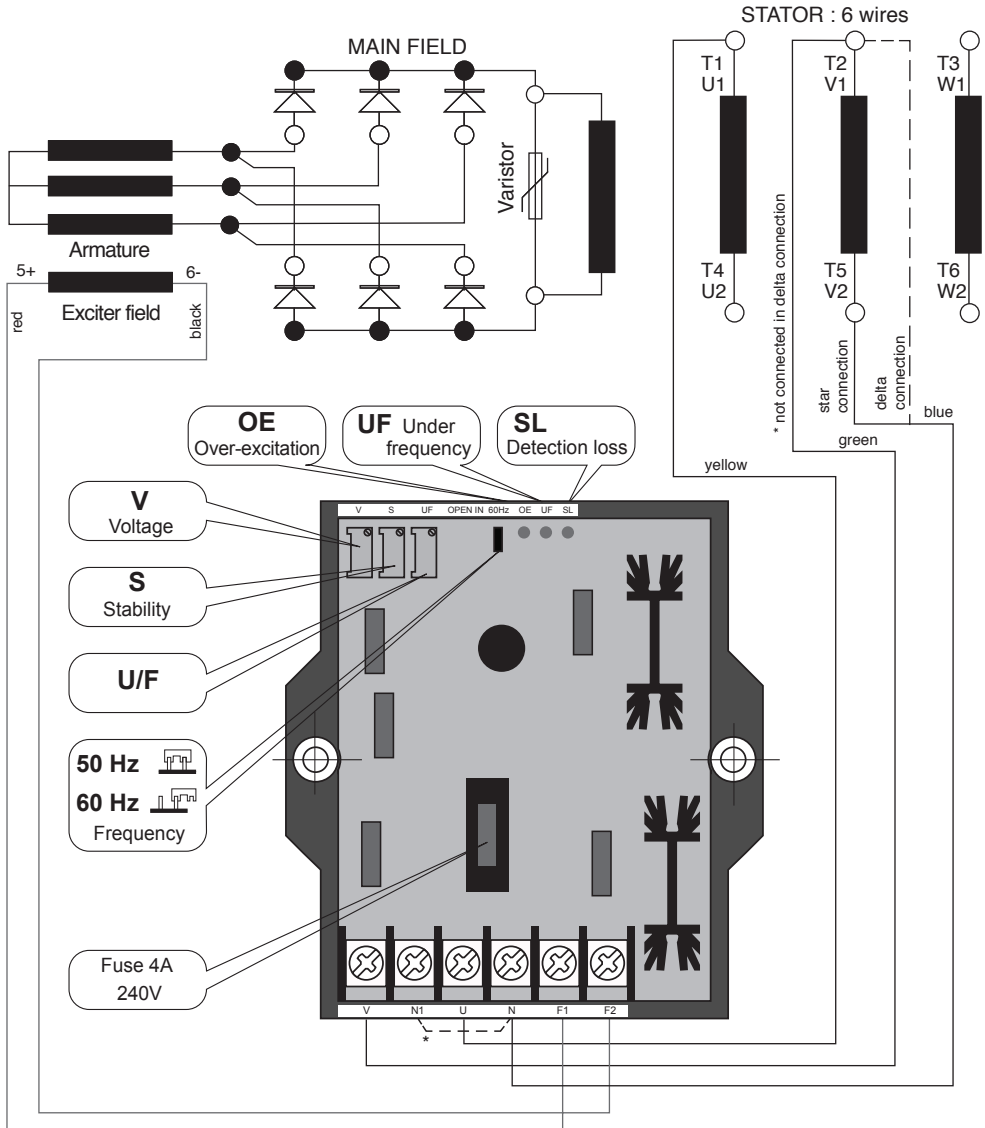

* Note: for delta connection (1PH - 3PH), use terminals N and U, short N and N1.

R120

A.V.R.

The AVR first builds up the generator voltage from its residual voltage to rated voltage.

When the generator is loaded, the sensed voltage goes down and generates the error signal, which is required to drive the closed loop system.

Depending upon the value of the amplified voltage, the ramp intersects the amplified voltage at the point which is early or late in the half cycle.

At the intersection point, a firing pulse is produced to trigger the power device.



Only qualified person should replace / operate on AVR.

Do not increase the voltage beyond the rated voltage.

5 - A.V.R. ADJUSTMENTS

5.1 - V-TRIM (V)

This feature is provided for voltage adjustment up to $\pm 10\%$ of rated voltage through a potentiometer. Turn the POT clockwise to increase voltage and vice versa, after reaching the nominal speed.

Default setting is 415V $\pm 2\%$ for 3 phase, 240V $\pm 2\%$ for 1 phase.

5.2 - FRO (UF)

This feature is provided to protect the AC generator from the sustained low speed operation through a potentiometer. AVR will reduce the voltage proportional to the speed below the set value.

The procedure to set the FRO pot is as follows (UF):

First run the generator at full speed (50Hz) turn FRO by few turns clockwise, ensure voltage does not increase. Now turn the FRO pot slowly anticlockwise. At a particular point Red LED glows and voltage will start to reduce, stop turning the pot at this point and turn the pot clockwise by two turns after nominal voltage is restored.

Factory default setting is 46Hz

5.3 - STAB (S)

This feature is provided to arrest the voltage hunting through a potentiometer. Turn clockwise to increase stability (to arrest oscillation). Too far clockwise rotation will result in sluggish response and sometimes oscillations also.

Factory default setting is slightly more than critical damping (around mid way).

6 - A.V.R. CONTROLS

Sl No	Control	Function	Direction
1	VOLTS	To adjust the generator output voltage	Turn clockwise to increase the output voltage
2	STAB	To arrest voltage hunting	Turn clockwise to increase the stability
3	UFRO	To set the Under frequency Knee point	Turn clockwise to to reduce the knee point

R120 A.V.R.

7 - TROUBLE SHOOTING CHART

Symptom	Cause	Action
No voltage build up	Fuse blown	Check & replace
	Low residual across U & N terminal	If the residual voltage of the Generator at rated speed is less than 2.5V AC (L-N), then disconnect the Regulator and connect a 24V DC Battery keeping F1 as positive & F2 as Negative. Connecting a free wheel Diode (BY 127) Right across the field with Diode Cathode to F1 & Anode to F2 during field flashing will help restoring the residual voltage. CAUTION: Remove the diode (BY-127) after field flash. 24V battery positive must be connected to F1 only & negative to F2. Reverse connection will Blow out Diode BY127 instantaneously.
	Incorrect wiring	Check wiring
	Rotating diodes and /or fuse failed	Check and replace
	Panel voltmeter defective	Check and correct
	AVR defective (repeated fuse blowing)	Replace after conducting static test
	Grounded exciter field	Check and Correct
High voltage build up	Loose, or no connection to 'U' terminal of the Regulator	Check and correct
	AVR defective	Conduct static test and replace if necessary
Low voltage build up	Low prime mover speed	Check and correct
	Sensloss is in circuit	Check & correct
	AVR defective	Replace AVR
Voltage oscillation	Incorrect stab-pot Sealing	Turn clockwise still Hunting is arrested
	Prime mover speed hunting	Check & adjust governor
	Load hunting, fluctuates rapidly	Check and correct
	High percentage of non linear load	Check and reduce the non linear load
	High reactance in generator (during non linear loading)	Consult generator manufacturer
Poor regulation	The exciter field's requirement is higher than 95V DC	Wrong selection or very low P.f load. Check & correct.
	Prime mover speed dips too much on load (kW load)	Adjust governor & reduce active load

R120

A.V.R.

8 - MULTIMETER CHECKS

Equipment: Digital Multimeter, Type: MECO or equivalent.

Select Diode mode in digital multimeter. Resistance between F1 & F2 (keeping common of multimeter jack to F1 of the AVR should give 0.4 to 0.6k Ω , and reverse keeping common of multimeter jack to F2 of the AVR should give **INFINITY**).

ZERO indicates power device failure in both the cases, No further tests (static test or dynamic tests) are allowed, and it will lead to rapture of fuse.

Resistance between F2 & U (both sides) should be 180k Ω .

Resistance between F2 & V (Keeping common of the multimeter to 'V' of the AVR should show about 2.2M ohms in 10M Ω range and reverse keeping common of the Multimeter to F2 of the AVR should give 15 Mega ohms.

ZERO indicates power device failure in both the cases, No further tests (static test or dynamic tests) are allowed, and it will lead to rapture of fuse.

Resistance between U&V should give 300k Ω to 400k Ω . Open circuit indicates AVR failure. In static test lamp will not turn OFF or when connected to generator it will produce ceiling voltage (for 3 phase ONLY).

Resistance between U&N1 should give 200k Ω to 260k Ω . Open circuit indicates AVR failure. In static test lamp will not turn OFF or when connected to generator it will produce ceiling voltage (for 1 phase ONLY).

Resistance between N&F1 should be very low or ZERO ohms. If it is open lamp will not glow when static test is conducted.

R120

A.V.R.

9 - STATIC TEST PROCEDURE

For 3-phase circuit

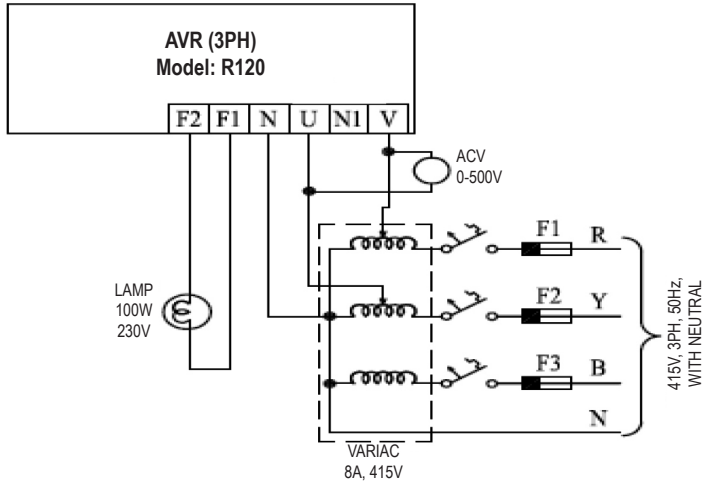

STATIC TEST CONNECTION DIAGRAM OF 3PH AVR

This should be attempted only after ascertaining that the regulator has passed all multimeter checks. Connect the regulator to three ph variable voltage source as shown in diagram 3 phase of this manual.

1. Keep 'V-TRIM' in minimum position.
2. Keep 'FRO' in fully maximum position.
3. Increase the applied voltage. The lamp should glow with increasing brightness. At a voltage around 360-380V the lamp should GO-OFF slowly. Further increase in voltage up to 415V should keep the lamp OFF. Decrease the voltage now to below 360 volts the lamp should glow bright again.
4. Turn 'FRO' pot anticlockwise the lamp should GO-OFF slowly. Now turn 'FRO' pot clock wise. The lamp should brighten up again.

5. It is difficult to prescribe a static test for checking the stability, as it is best found in closed loop test. However healthy regulator will behave as given below.

First keep the 'STAB' pot in fully anticlockwise. Conduct static test as in 1, 2 & 3, the lamp will GO-OFF rather swiftly at 360-380V and come again swiftly when the voltage is reduced below 360V.

Now keep 'STAB' pot fully clockwise, conduct static test as in 1, 2, & 3 the lamp should GO-OFF much slower and come again much slower. At end of this test keep pot mid-way.

If the regulator behaves as said above then the regulator is in operating condition.

R120

A.V.R.

For 1-phase circuit

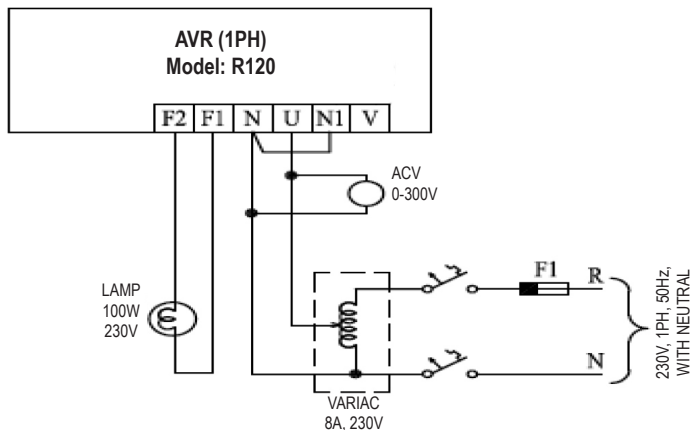

STATIC TEST CONNECTION DIAGRAM OF 1PH AVR

This should be attempted only after ascertaining that the regulator has passed all multimeter checks. Connect the regulator to single ph variable voltage source as shown in diagram 1 phase of this manual.

1. Keep 'V-TRIM' in minimum position.
2. Keep 'FRO' in fully maximum position.
3. Increase the applied voltage. The lamp should glow with increasing brightness. At a voltage around 200-220V the lamp should GO-OFF slowly. Further increase in voltage up to 240V should keep the lamp OFF. Decrease the voltage now to below 200 volts the lamp should glow bright again.
4. Turn 'FRO' pot anticlockwise the lamp should GO-OFF slowly. Now turn 'FRO' pot clock wise. The lamp should brighten up again.

5. It is difficult to prescribe a static test for checking the stability, as it is best found in closed loop test. However healthy regulator will behave as given below.

First keep the 'STAB' pot in fully anticlockwise. Conduct static test as in 1, 2 & 3, the lamp will GO-OFF rather swiftly at 200-220V and come again swiftly when the voltage is reduced below 240V.

Now keep 'STAB' pot fully clockwise, conduct static test as in 1, 2, & 3 the lamp should GO-OFF much slower and come again much slower. At end of this test keep pot mid-way.

If the regulator behaves as said above then the regulator is in operating condition.

R120

A.V.R.

10 - DIMENSIONS

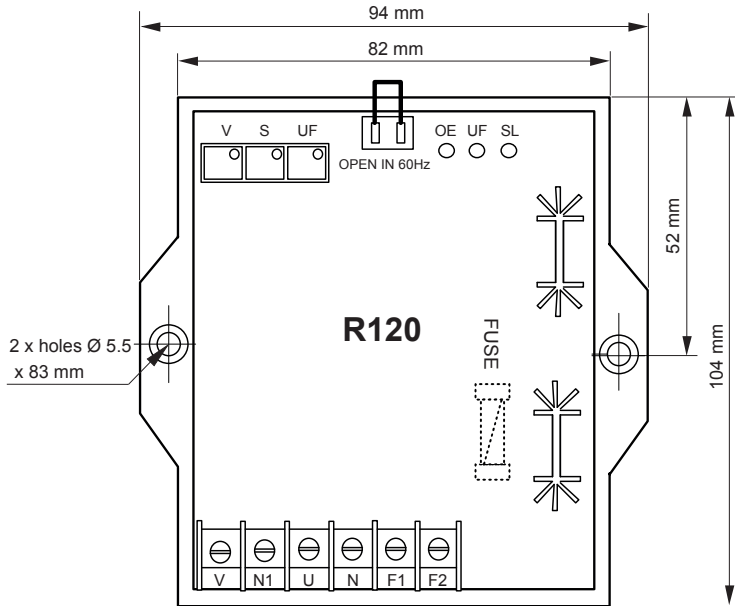

R120

A.V.R.

11 - SPARE PARTS

11.1 - Designation

Description	Type	Code
A.V.R.	R120	4969966

11.2 - Technical support service

Our technical support service will be pleased to provide any additional information you may require.

When ordering spare parts, you should indicate the type and code number of the regulator.

Address your enquiry to your usual contact.

Our extensive network of service centres can dispatch the necessary parts without delay.

To ensure correct operation and the safety of our machines, we recommend the use of original manufacture spare parts.

In the event of failure to comply with this advice, the manufacturer cannot be held responsible for any damage.

R120

A.V.R.

Disposal and recycling instructions

We are committed to limit the environmental impact of our activity. We continuously survey our production processes, material sourcing and products design to improve recyclability and diminish our footprint.

These instructions are for information purposes only. It is the user responsibility to comply with local legislation regarding product disposal and recycling.

Recyclable materials

Our alternators are mainly built out of iron, steel and copper materials, which can be reclaimed for recycling purposes.

These materials can be reclaimed through a combination of manual dismantling, mechanical separation and melting processes. Our technical support department can provide detailed directions on products dismounting upon request.

Waste & hazardous materials

The following components and materials need a special treatment and need to be separated from the alternator before the recycling process:

- electronic materials found in the terminal box, including the Automatic Voltage Regulator (198), Current Transformers (176), interference suppression module (199) and other semi-conductors.
- diode Bridge (343) and Surge suppressor (347), found on the alternator rotor.
- major plastic components, such as the terminal box structure on some products. These components are usually marked with plastic type information.

All materials listed above need special treatment to separate waste from reclaimable material and should be handed to specialized disposal companies.

The oil and grease from the lubrication system should be considered as a hazardous waste and has to be handled according to local legislation.

Service & Support

Our worldwide service network of over 80 facilities is at your service.

This local presence is our guarantee for fast and efficient repair, support and maintenance services.

Trust your alternator maintenance and support to electric power generation experts. Our field personnel are 100% qualified and fully trained to operate in all environments and on all machine types.

We know alternators operation inside out, providing the best value service to optimize your cost of ownership.

Where we can help:



Contact us:

Americas: +1 (507) 625 4011

Europe & International: +33 238 609 908

Asia Pacific: +65 6250 8488

China: +86 591 88373036

India: +91 806 726 4867

 service.egg@leroy-somer.com



Scan the code or go to:

www.lrsr.co/support

LEROY-SOMER[™]

www.leroy-somer.com/epg

[Linkedin.com/company/leroy-somer](https://www.linkedin.com/company/leroy-somer)

[Twitter.com/EPG_Alternators](https://twitter.com/EPG_Alternators)

[Facebook.com/LeroySomer.EPG](https://www.facebook.com/LeroySomer.EPG)

[YouTube.com/LeroySomerOfficiel](https://www.youtube.com/LeroySomerOfficiel)



Nidec
All for dreams